

# Lumos

**\*Yearly Physics Based Magazine**

**Volume -I 2023**



**Department of Physics,**

**Idhaya College of Arts and Science for Women, Pondicherry.**

**Publishing Partner**



**Eleyon Publishers- Royal Book Publishing,**

**51/1, K M Nagar, Ayodhiyapatnam, Salem.TamilNadu-636103.**

## PREFACE

For countless generations, the wonder of the cosmos has served to awe, fascinate, frighten, and ultimately humble mankind. How often have we gazed at the night sky and wondered why we even mattered in this vast, complicated, and utterly baffling universe? But how often have we let our curiosity get the best of us and we tried to figure out the mysteries of the cosmos and where we fit in it?

For our part, at Idhaya College of Arts and Science for Women, we were compelled to offer our perspective on the operation of physical law. This led to the conception of the magazine. Our goal in publishing this journal is to help you understand the numerous facets of physics. In this issue, we showcase works written by undergraduates on a wide variety of themes in an effort to highlight the beauty of physics. However, these pieces represent only a tiny portion of the magazine as a whole. Comic comics and physics trivia are only two examples of the physics-related content sprinkled throughout.

The many facets of college life at Idhaya College of Arts and Science for Women are also depicted in LUMOS. We've had some of the most memorable experiences as a group through our participation in campus organizations. Through his magazine, we wish to share some of his vitality, excitement, and joy.

Without the support of our administration, faculty, and contributors, this journal would not exist in its current form. For want of a better description, this trip has been spectacular.

Thanks and Regards,

LUMOS Editorial Team

### Book Details

**Title:** LUMOS

**ISBN:**9789395423618

**Publication Month and Year:** APRIL, 2023

**Volume:** I

**Chief Editor:** Dr. K. Shakila

## MAGAZINE COMMITTEE MEMBERS

### EDITOR-IN-CHIEF



**Dr. K. Shakila, Ph. D.**  
Head, Department of Physics,  
Idhaya College of Arts and Science for women, Puducherry

### EDITORS



**Prof. M. Adhilakshmi**  
Assistant Professor, Department of Physics,  
Idhaya College of Arts and Science for women, Puducherry



**Prof. A. Aani Vinoliya Margrate**  
Assistant Professor, Department of Physics,  
Idhaya College of Arts and Science for women, Puducherry

### CO-EDITORS



**K. AYUSHMA**  
III BSC PHYSICS



**M. ROHINI**  
III BSC PHYSICS



**V. KAAVIYA PRIYA**  
III BSC PHYSICS

### TECHNICAL SUPPORT



**Ms. P. Ramya**

Technician, Department of Physics,  
Idhaya College of Arts and Science for women, Puducherry

**I BSC PHYSICS, II BSC PHYSICS, and III BSC PHYSICS - ALL STUDENTS**

## HISTORY OF THE COLLEGE

Idhaya College of Arts and Science for women, a college affiliated to Pondicherry University was started by the Franciscan Sisters of the Immaculate Congregation and had its inception in the year 2004.

It was formed solely for women and caters to the needs of the rural, backward and marginalized womenfolk. It is indeed another milestone in the history of the Immaculate congregation.



The motto of the college is **“Arise and Shine”**

Which aims in moulding the youth to become strong and vibrant and to be agents of change for better living.

The college strives to impart value based education for the integral personality development of the students.

## SECRETARY MESSAGE

“Start by doing what’s necessary; and do what’s possible; and students - you are achieving the impossible”

The prime motive of our college is to develop a sound mind in a fine body or sound, so as the students can develop into a resident of rational thinking. The college adequately prepared the students to meet the competing future. The students are instilled with ethical standards and spiritual bias throughout their growing years. Excellence in education is our goal. We seek and adopt innovative methods to improve the quality of education on a consistent basis. Many awards, honors and recognition stand a testimony to our splendid and incredible journey, which motivates us to strive harder for further nourishment of the young minds. It keeps pace with an incipient culture and knowledge for the future competing transformation. Our pedagogy develops deeper opportunity for the young ladies to meet the challenging contingency with a holistic approach. We encourage exploring and nourishing the hidden potential and talent of all members. We kindle to induce the analytical skills, with a morale innovation in thought and action. Once again, I shower my affectionate greetings on the promising intellects of Idhaya and to realize the self-potentiality to the society.



With Regards,

Rev. Sr. Dr. A. Fathima, Ph. D.

Secretary, Idhaya College of Arts and Science for women, Puducherry

## DEPARTMENT OF PHYSICS

**“An investment in knowledge pays the best interest”- Benjamin Franklin**

The department started its journey in the year 2004 with huge dreams for the empowerment of women in the society. The department provides high quality education in Physics which paves the way for the enlightenment of future generations. Like engineering and medical field, the scope for the field also increases and the student strength shows the growth of interest in Physics.



Department of physics is one among the premiere departments in our institute. The positive teacher – student relationship has given good social and academic outcome. with a committed and highly qualified faculty, and a safe and secured environment to the students to have an innovative scientific mindset for outstanding performance and pioneering research mindset for the future research endeavors which create a greater research prospects for the country.

Our department comprised with the support of four well qualified, active, experienced teaching faculties and a lab assistant to train 150 students. The faculty members with specialization in different fields of physics have deeper interests in both academic teaching and research.

### VISION

Our vision is to impart great inquisitiveness and scientific inquiry into the minds of the younger generations for to stride in the global research arena.

We are sure, more and more students will choose this great subject as the chief vehicle to their ultimate success.

Our core values include integrity, innovation, passion, team work and empowerment.

### MISSION

We discover, develop and share knowledge.

As a center of academic excellence, we aim to provide the highest quality research led teaching and learning. Challenge the boundaries of knowledge, research and disciplines, enable our graduates and staffs to be exceptional individuals equipped to address global challenges, promote good health, economic growth, cultural understanding and social wellbeing.



## LAB FACILITIES

Our state-of-the-art physics laboratory is equipped with modern equipments to help the students learn the concepts of physics with experiments. The lab is quite spacious and very well ventilated to ensure proper availability of light in it. A dark room facility for optics experiments advanced Electronics lab and general laboratories to accommodate 50 students at a time. One just cannot resist loving both the lab and the subject as the aura of physics seems to besiege the invader.



## HOD MESSAGE

Since the department of Physics began its journey more than a decade ago, it has been simultaneously and successfully performing the multiple roles of creating new knowledge, acquiring new capabilities, and producing an intelligent human resource pool contributing in various domains of society. The Department has consistently had high growth goals, and its experienced, committed faculty members are passionate about creating the best learning environment possible. They are strongly committed to science education.



It is admirable that the department's level of knowledge has increased. According to the department's vision, students' holistic development is emphasized, instilling in them a habit of ongoing learning and a sense of obligation to contribute to the advancement of society.

The students are given technical knowledge through a routinely updated curriculum, which is complemented by an application-based environment in cutting-edge labs. The students are inspired to take part in the workshops, seminars, and paper presentations that are crucial to sustaining competency. At the departmental and university levels, several clubs are used to encourage cultural activities.

I commend the department's students for their enthusiastic responses to this proposal and their contributions in a variety of subjects. In addition, the faculty and student members of the magazine's editorial board deserve recognition for their hard work.

Best wishes and keep up the great effort!

With Regards,  
Dr. K. Shakila, Ph. D.  
Head, Department of Physics,  
Idhaya College of Arts and Science for women, Puducherry

## CHIEF GUEST MESSAGE

I am indeed happy that the Departments of Physics, Idhaya Arts and Science College, Pondicherry is organizing a National Conference on Materials Science on 25th April, 2023. in association with Indian SpectroPhysics Association (ISPA).



This conference is unique in the sense that it provides an opportunity to the Research Scholars, Students and Scientists to get together and discuss with open mind about the latest and emerging trends in the fields of Materials Science and spectroscopy. I always encourage research as it opens new avenues for invention and advancement.

I congratulate the Patron, Rev. Sr. Dr. A. Fathima, Secretary, Convenor, Dr. K. Shakila and all the organizers for their strenuous efforts exert towards arranging this National Conference in an ideal manner through virtual platform for the benefit of the Science Community.

I wish this Conference a grand success and my best wishes to all the delegates and participants to share their expertise and research findings.

With Regards,

Dr. S. Gunasekaran, M.Sc., Ph.D., D.Sc.

TANSA Awardee

Dean, Research & Development

St. Peter's Institute of Higher Education & Research Avadi, Chennai - 600 054, Tamil Nadu, India.

I am extremely glad that Department of Physics, Idhaya Arts and Science College, Pondicherry is organizing a National Conference on Materials Science on 25th January, 2023. This conference will provide leading scientists working in the field to share their latest research and engage in exciting discussions. This conference shall provide an international medium to share and exchange the theoretical and experimental studies and research and aims to bring together leading academic scientists, industrialist, research scholars, students, delegates and exhibitors to exchange and share their experiences, research results about all aspects of Materials Science.



My hearty congratulations to the Patron, Rev. Sr. Dr. A. Fathima, Secretary, Convenor, Dr. K. Shakila and his team for conducting this international scientific mega event as a successful one.

With Regards,

Dr. P. Janani, Ph.D

Instructional Designer Head (Academics), Ectian Content Private Limited Mumbai, Maharashtra

## CHIEF GUEST MESSAGE

I am delighted that the Physics Department of Idhaya Arts and Science College in Pondicherry is hosting a National Conference on Materials Science on April 25, 2023, in collaboration with ISPA.

This conference is unusual in that it allows Research Scholars, Students, and Scientists to debate new materials science and spectroscopic developments with an open mind. I support research because it leads to innovation.

I congratulate the Patron, Rev. Sr. Dr. A. Fathima, Secretary, Dr. K. Shakila, Convenor, and all the organizers team for their hard work in organizing this National Conference on a tangible platform for the science community.

All the best to the delegates and attendees at this year's conference for a fruitful exchange of ideas and information.



With Regards,

Dr. P. Ramesh Babu, Ph.D

Department of Electronics and Communication Systems,  
Sri Krishna Arts and Science College,  
Coimbatore, Tamilnadu, India.

## MESSAGE FROM THE FIELD EXPERTS

**Dr. S. Sivakumar**

**Assistant Professor**

**Department of Physics**

**Bharathidasan Government College for Women (Autonomous), Puducherry.**

Radiation is everywhere on Earth, including the atmosphere. The earth's crust contains primordial radionuclides  $^{232}\text{Th}$ ,  $^{238}\text{U}$ , and  $^{40}\text{K}$ , which emit natural radiation that affects all living things. Humans are exposed to external radiation, naturally occurring radionuclides in their environment, and internal radiation via food, water, and air. Thus, humans need beware of their natural environment's radiation health impacts. Radiation benefits humans in medical, academics, industry, and electrical generation. Radiation also benefits agriculture, archaeology, space exploration, law enforcement, geology, and others. Hospitals, doctors, and dentists employ nuclear materials and procedures to diagnose, monitor, and treat many metabolic processes and medical disorders in humans. Radioactive carbon dating is used by archaeologists to date fossils and other artefacts. Radiation removes hazardous emissions from coal-fired power stations and industry. Thus, radiation and nuclear technology that help society must be discussed.





## **Dr. M. Lakshmipriya**

**Assistant Professor**

**Department of Physics, School of Physical and Chemical Sciences  
B. S. Abdur Rahman Crescent Institute of Science and Technology, Chennai.**

In the 21st century, we use electronic circuits and devices in gadgets, home appliances, computers, transport systems, cell phones, cameras, TV, etc. Today's electronics have penetrated healthcare, medical diagnosis, autos, industries, electronics projects, and more, convincing everyone that without electronics, work is impossible. Thus, knowing the past and the brief history of electronics is essential to refresh our minds and be inspired by those who sacrificed their lives to make such amazing discoveries and inventions that



cost them everything but benefitted us immensely. Thus, the Physics Department organised a guest lecture by Dr. Lakshmipriya M on "Electronics – An Insight and its Evolution". Smaller components necessitated the IC. Before British scientist Geoffrey Dummer's first IC design, gadget size was restricted by the circuit board's ability to fit as many components as possible. The device's size was defined by the size of the wires, transistors, and other circuit components, which had to work together. Miniaturisation is made possible by the integrated circuit (IC). Smaller components made smart TVs, cell phones, and other devices possible. All three IC inventors had radar backgrounds. The seminar covered IC manufacture and packing. The seminar addressed epitaxial growth, photolithography, etching, diffusion, ion implantation, and circuit manufacturing. The resource person explained optoelectronics and certain devices. She completed the talk by listing the pros and cons of electronics advancement.

## **Ms. A. Aani Vinoliya Margrate**

**Assistant professor**

**Department of Physics, Idhaya college of Arts and Science for women, Puducherry.**

The biggest cause of water contamination is colours from the textile and photography industries. In this article, commercial dyes including Methylene Blue (MB), Congo Red (CR), and Procion Yellow (PY) are subjected to photocatalytic degradation under ultraviolet radiation (UV/TiO<sub>2</sub>). TiO<sub>2</sub> is an appropriate semiconductor for photocatalytic degradation. TiO<sub>2</sub> that is nanosized is chosen due to the different physical effects it has on photocatalytic activity. Here, the developed nano TiO<sub>2</sub> method and the outcomes of various TiO<sub>2</sub> characterisation approaches from prior studies were examined. Investigations have been done into how varied catalyst weights, starting concentrations, and deprecation PH affect degradation. As the dye concentration rose, the degradation rate in all three dyes reduced. The greatest photocatalyst is TiO<sub>2</sub>.



**Dr. K. Saravanan,**

**Assistant Professor (Medical Physics)**

**Department of Radiation Oncology, Regional Cancer Centre, JIPMER, Puducherry.**

Medical physics applies physics to medicine. All fields of physics—mechanics, electromagnetism, thermodynamics, nuclear physics, optics, fluids—have medical applications. Medical physics focuses on developing new diagnostic and therapeutic instruments. The body is complex. Physics may replicate numerous body functions. Physically based diagnostics and medical equipment include measuring body temperature, blood pressure, eye pressure, and heart rate. Medical imaging helps diagnose. X-rays, MRIs, ultrasounds, etc. Since tissues contain a lot of water, MRI uses nuclear magnetic resonance (NMR) to image atom nuclei, particularly the hydrogen atom (H). Soft tissue research and brain lesion diagnostics use MRI. Medical physicists explore new imaging and treatment methods and mentor Ph.D. and MD students. They also teach radiation, nuclear medicine, radiology, medical physics, and more. Radiation shielding is their speciality. 75% of medical physicists work in radiation. Cancer treatment includes radiation therapy, chemotherapy, and surgery. Gamma and high-energy X-rays precisely target cancer patients' damaged areas. External Beam Therapy and This radiation treatment uses a distant radiation source, unlike brachytherapy. The Medical Physicist measures dose, plans, and ensures quality to give a precise dose of irradiation to a cancer volume with little damage to healthy tissue. Medical physicists can influence nuclear medicine and radiodiagnosis. The Indian Atomic Energy Regulatory Board and Radiological Safety Division set medical physicist programme guidelines.



**Dr. G.SHAKILA**

**Assistant Professor**

**Department of Physics, Bharathidasan Government College For Women, Puducherry.**

Einstein invented physics. Einstein advanced maths and physics. Albert Einstein. He contemplated. His greatest contributions were relativity, mass-energy equivalency, and photoelectric effect. Einstein died 18 April 1955. His research taught physics. He stressed physics geometry. He wrote around 300 scientific papers. On December 5, 2014, universities and archives launched a 30,000-document Einstein display. 1905 saw four notable Einstein articles. Light occasionally acts like quanta, according to the original publication. The second investigation demonstrated heat theory and atoms. Einstein's 1905 study "Investigations on the theory of the Brownian movement" explained Robert Brown's pollen particle tests in liquid. His third paper addressed electromagnetic theory and ordinary motion's central question. Relativity did. The fourth proved mass-energy ( $E=MC^2$ ).



### **Ms. M. Adhilakshmi**

**Assistant professor**

**Department of Physics, Idhaya college of Arts and Science for women, Puducherry.**

The investigation utilised the reactive ball milling technique to create the magnesium ferrite nanoparticles. The produced materials were investigated by XRD, FT-IR, UV, SEM with EDAX, and VSM to determine their structure, vibrational frequencies, morphology, and magnetic characteristics. X-ray diffraction analysis showed that  $MgC_2O_4$  ferrites, having a space group of  $Fd3m$ , can crystallise into a cubic phase. The formation of the ferrite phase was detected in the FTIR spectra by the presence of bands at  $565$  and  $480\text{ cm}^{-1}$   $MgC_2O_4$ . The FE-SEM pictures reveal a porous, sponge-like structure caused by the extreme aggregation of nanoscale particles. Copper ferrite, as seen in the UV-vis spectrum, contrasts sharply with magnesium ferrite. Using a hysteresis loop, ferrimagnetic characteristics of Mg-ferrite nanoparticles were detected.



### **Dr. R.Arivuselvi**

**Associate Professor & Head,**

**PG and Research Department of Physics, Sri Vidya Mandir Arts and Science, Tamilnadu, India.**

Women's participation in physics education and the workforce has steadily improved over time. In 2018, 1,900 women obtained bachelor's degrees in physics and 350 earned doctorates. Over the past decade, women have earned 1-2 percentage points more physics bachelor's and doctorates. In 2007, women obtained 21% of physics bachelor's degrees and 18% of physics doctorates.

Physics has fewer women than other STEM fields. Women obtained 57% of bachelor's degrees in academics, not only STEM. Women obtained 60% of bachelor's degrees in biological science, 50% in chemistry, 40% in mathematics, and 35% in astronomy, according to 2017 NCES data. Physics, engineering, and computer science bachelor's degrees were barely 20% female.

Women now make up nearly all physics faculty. Women face many physics challenges, but we should also emphasise their triumphs. Women are underrepresented in physics (20%), but academic departments are seeing an increase. In 2018, 32% more women than men were hired for tenure-track or permanent roles. Most women (60–80%) report positive PhD programme and career experiences. 29% of women report workplace and school sexual harassment. Women suffer more with work-family balance, especially maternity leave and child care. More women than males shift their work schedule, become stay-at-home parents, and report slower professional growth.



### Prof. K. Srinivasa Raghavan

The Greek term "physics" means nature, therefore "physics." Thus, physics is understanding the physical cosmos. Lord Ernest Rutherford was a remarkable scientist who respected physics and nature and attained immortality and Olympic position in his lifetime.

New Zealand birthdate: August 30, 1871. He attended many schools. He attended Nelson College and Canterbury College to study mathematics, physics, Latin, English, and French. M.Sc. mathematics and physics followed. Inspired by Nikola Tesla, he studied iron magnetism at very high magnetising current frequencies. He built two devices for this study: a timing device that could switch circuits in  $10^{-5}$  seconds and a



magnetic detector of very fast current pulses. He earned an M.A. with double honours in mathematics, mathematical physics, and physical science (Electricity and Magnetism) in 1893. He left New Zealand in 1895 as a renowned researcher and innovator. He joined Cambridge University in England under J. J. Thomson. He moved to Manchester University. His main focus was radioactivity and gas conduction. Radioactivity was his 1904 book. He found two types of rays in radioactive emission. He called them alpha and beta rays. His most notable work on atoms scattering alpha particles was done with Neil Bohr, Mosley, Chadwick, and others. "The Newton of Atomic Physics" was his nickname. He shaped nuclear physics and atomic structure.

He was a brilliant theoretician and meticulous experimentalist. His other accomplishments include artificial nuclei disintegration, sonic submarine detection, conversion of heavy elements into lighter elements, identification of alpha particles as helium nuclei nuclear model, dating the earth, and electrical detection of individual nuclear particles. First smoke detector, Rutherford-Geiger detector.

Rutherford excelled. His students called him "the crocodile" since crocodiles don't turn their heads. Rutherford immersed himself with research. He is the most famous scientist of all time. His journey from rural youngster to immortality is unprecedented."

## SEMINARS

Department of Physics organized half a day seminar on “Albert Einstein Father of Modern Physics – an Overview”, on 18<sup>th</sup> November 2022. The resource person to this seminar was Dr. G. Shakila, Assistant Professor, Bharathidasan government college for women. As Albert Einstein is justly famous for devising his theory in an intellectual way. The seminar also focused on the Einstein’s important contribution in Quantum Mechanics.



Department of Physics organized a seminar on the topic “Radiation Spectroscopy” on 16<sup>th</sup> December 2022. The resource person was Dr. S. Sivakumar, Assistant professor, Bharathidasan Government college for Women. He shared the facts in the field of Radiation Spectroscopy that enriched the students’ knowledge.



A seminar on “Role of Physics in Medical Field” was organized by our department on 24<sup>th</sup> March 2023. Dr. K. Saravanan, Assistant Professor, department of Radiation Oncology, JIPMER. This seminar was an eye opener for the students in the field of Medical Physics. Students were introduced to courses like radiology, radiography, medical physics and much more. After this seminar, they were able to figure out their future as a physicist in the field of medicine.



### **GUIDANCE AND COUNCELLING SEMINAR:**

On 22.07.2022, guidance and counseling seminar for Science department students was organized at Idhaya College of Arts and Science for Women by the College Administration. Dr. Poorani, Happiness and Success Academy, Pondicherry was the primary speaker of the seminar. She spread out her knowledge to the students and gave her first copy of the books to the students with the motive of encouragement. All the students interacted with her very well and made that session very successful.



### **EXPERIMENTAL PHYSICA:**

A workshop on the theme “Experimental Physica” was conducted by the Department of Physics. Mrs. K. Sivakamasundari, Asst.Professor, Saradha Gangadharan, College, Puducherry was the Chief Guest for the workshop. She emphasized the importance of scientific thinking and encouraged the students to proceed their higher studies in research field. Over 60 students attended the workshop and displayed their working models. The final year student Subhashini.S won the first prize followed by first year student Priyadharshini won the 2<sup>nd</sup> prize and Janaranjini.S of final year won the 3<sup>rd</sup> prize.



### **ORIENTATION PROGRAMME:**

The freshers participated in orientation on 02.02.2023 and 03.02.2023. S.S. Jayakumar Lawrence, Director, Head DESIFMA, Former Professor, Media Studies, Loyala College, Chennai, was the resource person for this programme. Personality development, digital photography, and RJ/VJ were added by him. These courses helped students strengthen their skills.



### **THE PATH TO SELFLESSNESS, POSITIVITY AND INNER PEACE:**

Bro. J. Rajesh, Managing trustee, JIREH. Mission trust, Gospel worker cum motivator, Coimbatore was the speaker of the day February 7<sup>th</sup> 2023. The students were motivated to stay positive and their inner peaces were discovered through his speech. With his spirituality he taught the students that “The mind and body are not separate, what affects one affects the other”. Finally the students left the auditorium with the wholesome heart.



### **MOTIVATIONAL PROGRAMME:**

It is tough to move through life without the much needed motivation. On 13.02.2023 & 14.02.2023. The motivational seminar has been conducted in Idhaya Auditorium. The students were motivated in the right path by Mr.K. Pugazhenth, Skill bench, training and placement academy. The session released stress and depression of the students and it made them feel a better human being. He explained the students about the importance of rules and regulations that were imposed on them and the way to make their parents happy by improving themselves in life. Mr. Pugazhenth made the students leave the auditorium with heavy heart and tears filled eyes.



### **CYBER SECURITY AWARENESS PROGRAMME:**

The students of second year from Department of Physics attended the awareness program on February 16<sup>th</sup> 2023 titled “Ethics and unethics of technology and cyber crime” organized by PG and research Department of Commerce, St. Joseph college, Cuddalore. By attending this programme, the students learned to face the upcoming challenges in the field of cyber system/crime/security. This Programme was a disclosure for the minds of students about the field of Cyber security.



### **FACULTY DEVELOPMENT PROGRAMME:**

Staff from Department of Physics attended the Faculty Development Programme conducted in Idhaya College auditorium on 23.02.2023 and 24.02.2023. The programmes focused on functional area expertise improving one's classroom delivery both as a teacher and trainer, enhancing the abilities for conducting meaningful research.

Dr. Victor Louis Anthuran, Former Professor, Loyola institute of Business Administration, Chennai, was the speaker of this programme. All the faculties participated and benefited by his speech.



### **CONVENTION MEETING:**

Staff's from Department of Physics Dr. K. Shakila and Mrs. M. Aadhilakshmi attended the convection meeting held in Pondicherry University on 1<sup>st</sup> march 2023. This brings the professionals together to discuss important issues or the topics in the field. The gathering was in order to discuss or engage faculties in some common interest.



### **BIRTH ANNIVERSARY OF MEGHNAD N. SAHA:**

On account of the birth anniversary of Meghnad N. Saha, Dr. APJ Abdul Kalam Science Center and Planetorium conducted a seminar on 5.10.2022. In the presentation having Dr. K. Sivakamasundari, Assistant Professor, Tagore Arts and Science College, Puducherry, we discussed about "Saha's Ionization Theory", she shared her thoughts on this theory that enriched the students knowledge about Meghnad Saha's lifestyle and his Ionization theory.





## ADD ON COURSES

In order to boost the efficiency of students and develop their knowledge and skills certain certified courses like Aari work, personality development and Digital photography classes were arranged by the institution.

### **Aari work:**

To encourage the hobbies of students in the field of art and craft, Aari work was introduced. It needs nothing but a needle and few other materials such as pearls, beads, decorate a fabric to design of our choice.

This work reduced the stress, cleared their mind and helped the students to stay focused.



### **Personality development:**

Personality development is the need of the hour as it is essential for the holistic development of children on their survival in this competitive world.

The classes are taken by Professor Laren Jeyakumar MD of DESIFMA who is well versed in motivating and training personality development. Students from Department of physics took a very keen interest and they were stuck to learn the way to enhance their personality through the classes.

### **Digital photography:**

Digital photography is a technology that uses digital camera to capture images. This courses helps the students to learn about digital camera's and the use of different equipment. Mr. Jagan, Associate director of DESIFMA, teaches this course to our students. In this class our students get to know about the working and types of camera's operating the camera, elements of framing, pillars of camera, angles, lightning etc.

## STUDENT CORNER - SCIENCE

### WORKING MODEL- SMART HELMET:

Accidents can be avoided with the help of smart helmets, and drunk drivers are discouraged from getting behind the wheel. The smart helmet uses an alcohol detector placed away from the driver's face to prevent them from operating a vehicle if they have been drinking. A radio transceiver is attached to the handlebars of the bicycle, and a transmitter is installed in the rider's helmet. It also contains the buzzer. Using the source of a sound to halt or resume anything. Arduino UNO setup is the main programme. Other components include a 12V battery, a switch, and jumping wires; a DC gear motor; a 5V relay; a BC 547 transistor; a 220 ohm resistor; and RC transmitters and receivers. The light bulb is located near the buzzer. The symbol for "on" or "off" can be shown there. The MQ3 breathalyser is worn in the area of the head covering the mouth. The alcohol-sniffing sensor will immediately shut off the DC gear motor in the wheel.

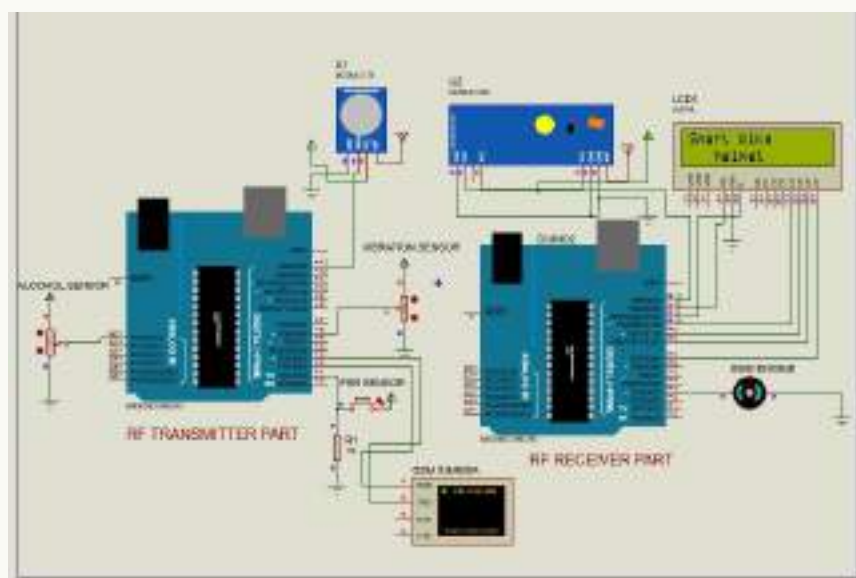

Karkuzhali Raja  
B.Sc Physics

## WORKING MODEL- HAND CLAPPING LIGHT CONTROLLER:

### FUNDAMENTAL CONCEPT:

The fundamental concept of the clap switch is that the microphone used in this circuit receives the clap sound and generates a small signal to controls a lamp . Generally this switch is operated through sound. For instance, light ,fan, TV can be controlled through clapping.

### COMPONENTS REQUIRED:

IC 4017, IC741, Resistors (10K,22K,1K,470 OHM,100 OHM), Red LED, Green LED, Microphone, BC 547, Battery.

### CIRCUIT DISCRPTION:

- The main component of this circuit is the electric condenser microphone. Microphone converts the sound of a clap into electrical energy which is inverted and fed to the IC 741. It amplifies the sound.
- Resistors and PCB pot connected on pin 3 of the IC 741 are used to adjust the sensitivity of the clap switch. The amplified output pulses from the operational amplifier IC 741 are passed into the input pin 14 of CD 4017.
- The IC CD 4017 receives a clock signal through the clock input and it turns ON all the 10 outputs one by one, every time it gets the clock input pulse. When you clap once, the relay is activated and load is turned ON. When you clap for the second time, the relay is deactivated and the load connected to the relay is turned OFF.

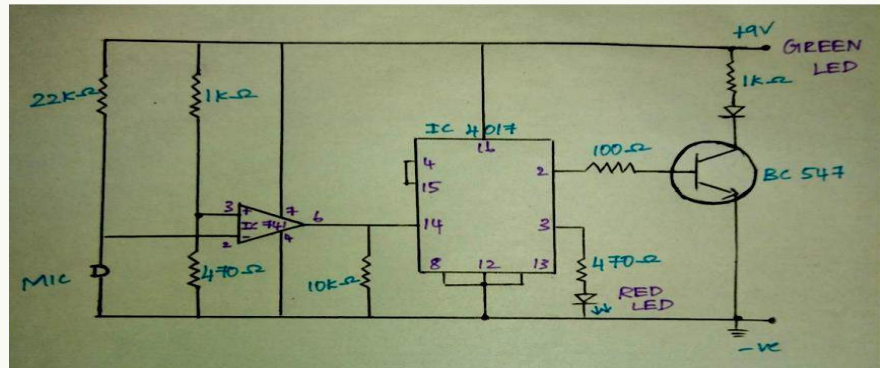

**Subashini .S**  
**B.Sc Physics (III year)**

## WORKING MODEL OF FIZEAU'S METHOD:

### APPARATUS:

The light from the source S was first allowed to fall on a partially silvered glass plate G kept at an angle of 45 degree to the incident light. The light then was allowed to pass through a rotating toothed-wheel with N teeth and N cuts of equal widths, whose speed of rotation could be varied through an external mechanism. The light passing through one cut in the wheel will get reflected by a mirror M kept at a long distance d, about 8km from the toothed wheel. If the toothed wheel was not rotating, the light reflected back from the mirror would again pass through the same cut and reach the eyes of the observer who looks through the partially silvered glass plate.

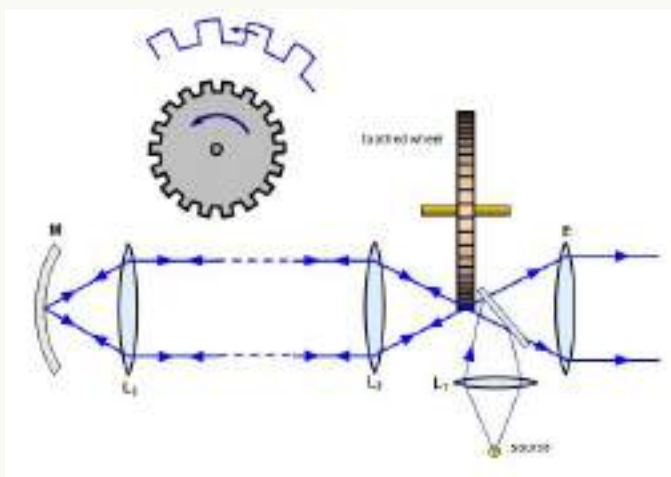

If the toothed wheel was not rotating, the light reflected back from the mirror would again pass through the same cut and reach the eyes of the observer who looks through the partially silvered glass plate.

### WORKING:

The angular speed of rotation of the toothed wheel was increased from zero to a value  $\omega$  until the light passing through one cut would completely be blocked by the adjacent tooth. This is ensured by the disappearance of the light while looking through the partially silvered glass plate.

### EXPRESSION FOR SPEED OF LIGHT:

The speed  $v$  of light in air is equal to the ratio of the distance the light travelled from the toothed wheel to the mirror and back  $2d$  to the time taken  $t$  implies

$$V = 2d/t$$

The distance  $d$  is a known value from the arrangement. The angular speed  $\omega$  of the toothed wheel when the light disappeared for the first time is,

$$\omega = \theta/t$$

Where,  $\theta$  is the angle between one tooth and the next slot which is turned within that Time  $t$ .

$$\Theta = \text{total angle of the circle in radian} / \text{no of teeth} + \text{no of cuts} = \frac{2\pi}{2N} = \frac{\pi}{N}$$

$$\text{Substituting } v = 2d/\pi/N\omega = 2dN\omega/\pi$$

Fizeau determined the speed of light in air as  $v = 2.99792 \times 10^8$  ms.



### PHYSICS BEHIND TOUCH SCREEN:

Touch screens work using electricity. The screen is made of glass; an insulating material it cannot carry an electric current. The surface of the screen is therefore coated with a thin layer of an electrically conducting material such as Indium tin oxide. This is chosen because it is transparent.

The conducting layer is connected to a low voltage so that for a short time, there is a tiny electric current on the screen. This leaves it with a small electric charge.

When your finger touches the screen, some of the small electrical charge flows on to it. Sensitive detectors round the edge of the screen can detect which point on the screen has lost charge so that it knows which point has been touched. If you are wearing gloves the screen won't respond because the material of gloves is an insulator.



Subashini S  
B.Sc Physics (3<sup>rd</sup> year)

### LI-FI TECHNOLOGY:

My Experimental project was on the topic (Li – Fi) Light fidelity technology which is a bi-directional wireless system that transmits data via LED or infrared lights. I used LED's for transmitting the data. The project which was required for me to make this setup was Audio Jack, speaker, LED, battery (9V), and solar panel connected the battery to the LED. Connect the solar panel to the speaker with the Audio Jack. Then connect the phone with the LED wire. When the phone is connected to LED, the LED glows and emits light. When this light is kept opposite to the solar panel and a sound is played in the phone. The song data gets transmitted via the LED and the speaker plays the song which is being played in the phone. Li-fi is evolving to overcome the rate speed in Wi-Fi, while using Li-fi the rate speed can reach up to 14Gbps. This paper presents an introduction of the Lifi technology including the architecture, modulation, performance and the challenges. There are numerous applications of Li-fi technology, it can be used in operation theatres, where wi-fi is not allowed due to radiation concerns. Li-fi can be used as a powerful means of communication in the field of disaster such as earthquakes or hurricanes. The average people may not know the protocols during disasters. As light is everywhere and free to use, there is a great scope for the use and evolution of Li-fi technology. If this technology becomes mature, each Li-fi bulb can be used to transmit wireless data. Although there is still a long way to make this technology a success. By developing this technology, we can migrate to greener, cleaner, safer communication networks. Therefore, there is certainty of development of future applications of the Li-fi which can be extended to different platforms.



MRohini  
(B.Sc Physics 3<sup>rd</sup> year)

## TIME TRAVEL PARADOXES

### BOOTSTRAP PARADOX:

A bootstrap paradox is a type of paradox in which an object, person, or piece of information sent back in time results in an infinite loop where the object has no discernible origin and exists without ever being created. What if you travelled back in time when Isaac Newton had not yet discovered gravity and taught him about the laws of gravity? So who discovered it—you or Newton?

### Grandfather Paradox:

Let's suppose you have a time machine that allows you to travel back into the past. While you're there, you accidentally kill one of your grandparents or any other direct ancestor before they have any offspring. That would alter a whole chain of future events, including your own birth, which would no longer happen. But if you weren't born in the future, then you couldn't kill your ancestor in the past, hence the paradox. It's a scenario that becomes popular in science fiction magazines.

### My opinion on time travel paradoxes:

By analysing these two paradoxes, many people are fascinated by the idea of changing the past or seeing the future before it happens. Time travel is theoretically possible. But that does not mean you can change the past. If time travel takes place, the traveller risks colliding with themselves and other objects in the past. From my point of view, time travel is a huge disaster.

### ROAD ACCIDENT PREVENTION MODEL:

My working model is based on the prevention of vehicles entering the wrong side of the road. Most road accidents enter the wrong side of the road. This can be prevented by a simple model with a rising gate. The model consists of a DC motor, battery, button, wires, gate and a barrier. The button is fixed under the road or on the road. The button serves as a key in the circuit. The button is connected to one of the terminals of the battery. The other terminal of the battery is connected to the motor. The gate is fixed near the barrier and it is rotatable. It is fixed to a DC motor. This set up is done on both sides of the road and a way is provided in between the roads. When a vehicle travels on the wrong side of the road, the button is pressed by it. This in turn activates the DC motor. The gate starts rotating and rises up showing the vehicle to stop. Thereby, the vehicle returns to the correct side of road.



A. Jasmine Philo II Year  
Department of Physics



C. Udhaya  
(B Sc Physics 3<sup>rd</sup> year)

## POSTER MAKING COMPETITION:

Poster Presentation competition on “Physics Today” was organized by Department of Physics on 21.09.2022 to encourage the students to think and share innovative ideas in the field of Physics. Students displayed their artistic skills through an array of posters with immense enthusiasm.



Marie Curie's full name Maria Salomea Skłodowska. She was born on 7<sup>th</sup> November 1867, Warem and died in 4<sup>th</sup> July 1934, France. She was awarded “The Nobel Prize” in Chemistry (1911) and “The Noble Price” in physics (1903). She discovered about Radium & Polonium, they are radioactive elements. She continued to investigate their properties. In 1910, she successfully produced radium as a pure metal, which proved the new elements existence beyond doubt. She was the first female professor at Sorbonne University. Madame curie shared the Nobel prize with her husband French physicist Pierre Curie on 1903.



**Hindhuja.K**  
**B.Sc Physics (3<sup>rd</sup> year)**



BIRTH : 14th March 1879 at German Empire

DIED : 18th April 1955 at New Jersey (U.S).

IQ level : "160" where normal IQ is from 85 -115.

FIELD : Physics, Philosophy.

AWARDS : At 1921 he received "Nobel prize" in physics for discovery of law of photoelectric effect and his work in theoretical physics.



## WOMEN SCIENTISTS

### Mary Anning (1799 - 1847)



When you say the tongue-twister "she sells seashells by the seashore," you're actually paying homage to this English fossil hunter! Mary Anning began searching for fossils on the cliffs of Dorset, England, as a means for extra income, but at the age of **12**, she made several discoveries that would rock the scientific world: the first known ichthyosaur fossil and the first two plesiosaur skeletons. Throughout her life, she made many observations that

led to revolutionary new understanding of prehistoric creatures, but she could never participate in a full scientific life because of her gender. She was ineligible to join the Geological Society of London, although her discoveries were critical to driving scientific inquiry into new explanations for natural history and set the stage for Charles Darwin's articulation of the theory of evolution a generation later. It was not until many years after her death that her influence was recognized. In **2010**, the Royal Society named her one of the top ten British women in the history of science.





### **Maria Merian (1647 - 1717)**



Before German-born naturalist and scientific illustrator Maria Merian began to study the life cycle of butterflies, most people believed that they were “born of mud,” spontaneously generated out of the earth. Her interest in insects was unusual; they were considered “vile and disgusting” and hardly worth study. She was also one of the first naturalists to observe insects directly, giving her remarkable insights into the way they really lived. Although she emerged as one of the leading entomologists of her day, since she wrote in German and not in Latin, the official language of science at the time, her remarkable discoveries about the metamorphosis of insects were ignored by many scientists. She also raised eyebrows by funding her own, unofficial expedition to Suriname where she described many new insects and plants; a highly unusual venture for a woman of the period to undertake. Even so, her impact on science is undeniable: many of her classifications are still valid today and her exquisite paintings of plants, animals, and insects have been widely admired throughout the centuries.



### **Henrietta Leavitt (1868 - 1921)**



Today, a computer is a machine, but in Henrietta Leavitt’s day, the term referred to a group of female astronomers who had been hired by Harvard to analyze data from their observatory. Edward Charles Pickering, who hired Leavitt, assigned her to look at variable stars: these stars brightened and dimmed at predictable intervals. Using the data provided to her, Leavitt identified and classified over 2,400 of these stars – and discovered that there was a relationship between the period and the luminosity of a particular type of variable stars, the Cepheids. This discovery changed the way astronomers saw the universe: not only did it allow scientists to measure the distance to remote galaxies, but it also paved the way for a new understanding of the structure and scale of the universe.



### Lise Meitner (1878 - 1968)



Lise Meitner, an Austrian physicist, made an extraordinary contribution to nuclear physics -- but she did not share the Nobel Prize for the discovery. The first woman professor of physics in Germany, Meitner frequently worked in partnership with Otto Hahn, a chemist. Even after Hitler came to power and Meitner was forced to flee to the Netherlands, she continued to collaborate with Hahn by correspondence. When Hahn's experiments showed that the nucleus of uranium could break apart, it was Meitner's physics that explained exactly what was happening - nuclear fission -- but the Nobel Committee awarded the prize to Hahn alone. After the committee's sealed records were made public and revealed how they had severely undervalued Meitner's contributions, she received numerous posthumous honors, among them the naming of element 109 meitnerium.



### Alice Ball (1892 - 1916)



In her short life, African-American chemist Alice Ball revolutionized treatment for leprosy. Ball was the first woman and first African American to receive a Master's degree at the University of Hawaii. While there, Dr. Harry Hollmann asked her for assistance analyzing chaulmoogra oil, which had shown promise as a treatment for leprosy -- the cause of a growing public health crisis in Hawaii -- but was difficult to use effectively. Ball developed a way to isolate the active ingredients of the oil, allowing them to be injected. Tragically, Ball died of an illness before she could publish her results, and another chemist later published without giving Ball credit. Fortunately, Hollmann ensured her name would be remembered, publicly declaring, "After a great amount of experimental work, Miss Ball solved the problem for me... [this preparation is known as]... the Ball Method." Ball's treatment remained the best option for leprosy patients until the mid-1940s, and today, Hawaii recognizes the impact of her work by celebrating Alice Ball Day every four years on February 29.



### **Gerty Cori (1896 - 1957)**



Growing up in what is now the Czech Republic, Gerty Cori knew that women were marginalized in science and medicine, but with the encouragement of her family, she was determined to study medicine. In 1922, she and her husband, Carl Cori, immigrated to the United States and began medical research. Although they were discouraged from working together as a married couple, their partnership was tremendously productive, resulting in dozens of papers. Together, they discovered the Cori cycle, which showed how the body uses chemical reactions to turn carbohydrates in muscle tissue into lactic acid, then remetsabolizes it, and they identified the catalyst, the Cori ester. On her own, Cori also studied glycogen storage disease and became the first person to show that a defect in an enzyme can cause a human disease. The Cori cycle earned the couple the 1947 Nobel Prize, making Cori the first woman to receive a Nobel for medicine.



### **Rachel Carson (1907 - 1964)**



When American marine biologist Rachel Carson published *Silent Spring*, she didn't just call attention to the dangers of indiscriminate use of synthetic pesticides; she also helped launch the modern environmental movement. Carson began her career in the U.S. Fish and Wildlife Service, but after articles and books that she wrote about ocean life became extremely popular, she started writing about science full time. When *Silent Spring* was released in 1962, Carson stood strong against intense criticism from the chemical industry, despite a simultaneous battle against breast cancer that was outpacing her treatments. Even after Carson's death, her book fueled public interest in environmental and public health issues and, within a few years, the Nixon Administration formed the Environmental Protection Agency. "*Silent Spring*" is widely considered one of the twentieth century's most influential works of non-fiction.



### **Dorothy Hodgkin (1910 - 1994)**



A British chemist, Dorothy Hodgkin was a pioneer of X-ray crystallography, a method that allows scientists to study the three-dimensional structure of molecules. Her confirmation of the structures of penicillin and vitamin B12 won her the Nobel Prize in Chemistry in 1964; to this day, she remains the only British woman to have received a Nobel in the sciences. She was particularly determined to identify the structure of insulin; the complex but critical molecule had been a mystery since its discovery. In 1969, 35 years after she first received a sample of crystalline insulin and

despite worsening rheumatoid arthritis that required her to use a wheelchair, Hodgkin finally confirmed its structure. She went on to spend the rest of her career assisting with insulin research and speaking for diabetes awareness.



### **Bibha Chowdhuri (1913 -1991)**

Physicist Bibha Chowdhuri is one of the early contributors of science — and has a ‘star’ named after her. In December 2019, the star which is nearly 340 light years away from us, was named ‘Bibha’ to honour Indian women's contribution in science. Chowdhuri, who was known for her work on elementary particle physics and cosmic rays, was also the only girl student in her master’s course in Physics in 1934. She completed her post graduation from Calcutta University, after which she was actively involved in research projects in Physics. She has also worked with Vikram Sarabhai, who is referred to as father of India’s space programme.



## HISTORY AND PHYSICS:

“To remember one’s roots and go back to them occasionally makes a human.” As a lover of history, I’m concerned with what it carries.

History and Physics are inseparable. But history is often disregarded in the study of physics, even though physics comes through it. There are a continuum of events in the past that contribute to the present advanced physics. History involves ideas, theories, equations, faults, flaws, serendipities that become the foundation of future improvements. Learning physics through history makes the process easy and intelligible. It makes us aware of the stories, incidents and serves as a sequel to physics. To the one who loves physics and wishes to excel in it, your strenuous efforts go in vain if you have zero knowledge in the history of Physics. No scientist would have falsified, improvised and formulated any theory without knowing the past. In my opinion, meticulous and cheek to cheek comprehension of the history of Physics could be profitable to future physicists and scientists. I advice everyone to keep in mind that “History is also equally important.”

**“Science taught... without a sense of history is robbed”.**

## PITCHBLENDE:

Pitchblende (pronounced as ‘pich-blend’) is a blackish brown mineral. It was first found by a research done by Marie Curie . It is a rich source of Uranium,so at present it is called ‘Uranite’ .In 1898, French phycists Pierre Curie and Marie Curie discovered Radium and Polonium from pitchblende , which was produced as a byproduct of Uranium’s radioactive decay.Curie was the first who used a radiation measurement to trace the minute amount of unknown radioactive substance present in pitchblende.They used the Curie Electrometer to identify the radioactive fractions . By using this ,they discovered 2 fractions , one containing mostly bismuth , the other containing mostly barium ,but both are strongly radioactive substance. After their research , in July 1898 , they conclude that , the Bismuth fraction contains a new element it has the same chemical property like bismuth but it is a radioactive element , they named as ‘Polonium’ (Marie’s birth place Polland). In December 1898 , they discovered and published that the barium fraction contains a radioactive element called ‘Radium’(in latin Ray) . Finally , the chemical properties of Radium and Polonium were completely dissimilar , but both are strongly radioactive substances.



**Revathi K**

**B.Sc Physics (2<sup>nd</sup> year)**



**S. Janaranjini**

**B.Sc Physics (3<sup>rd</sup> year)**

### **FIELD TRIP:**

Final year students of department of physics were taken to Dr. APJ Abdul Kalam Science Center and Planetarium setup by the National Council of Science Museums. Students enjoyed the fun side of science in an highly entertaining ambience and was an eye opener for the students in the field of marine diversity. Several scientific experiments and live models kept the students amazed throughout the trip.



### **NAAC ACCREDITATION MEETING:**

The authority members of Idhaya College arranged for a FDP for staff members in order to discuss about the importance and procedure to get NAAC Accreditation for the college. This seminar was presented by Dr. A. Joseph Selvakumar, Associate Professor and Head - Information Technology, IQAC, Co-ordinator, Idhaya Engineering College, Chinnasalem.



### **INTELLECTUS PHYSICA:**

Quiz competition on the theme “Intellectus Physica” was organized by the Department of Physics on 16.12.2022. The energy & enthusiasm of the students brightened the competition. This competition helped the students to gain some basic ideas on the method of preparing for the competitive exam. The quiz was energizing and at the same time informative. After completing the initial selection process, 3 teams were finalized. Finally, the students of team B won the First prize.



## STUDENT CORNER – ARTS

### COVID-19 VACCINATION CAMP:

Covid-19 vaccination camp was conducted by the members of PHC, Lawspet, Puducherry on 05.08.2022. During the camp students and faculties of Idhaya College got vaccinated with Covi-shield. Principal, Rev. Sr. Cyrina Anthoniyammal, Secretary, faculties expressed their gratitude to the doctors and the supporting staffs of PHC for the smooth conduct of the camp.



### 75<sup>TH</sup> INDEPENDENCE DAY CELEBRATION:

On 15<sup>th</sup> of August 2022, Idhaya College celebrated India's 75<sup>th</sup> Independence day where students, faculties and non-teaching staff paid their tribute to the Nation and the Freedom Fighters of India. Our Chief Guest Dr. S. Gopalan, Principal of Mother Teresa Institute of Health Science, Pondicherry hoisted the flag.



Prizes were distributed for the winners in various competitions in which I B.Sc., department of physics students of Physics Department won the 1<sup>st</sup> prize in drama and singing competition. II B.Sc., department of physics students of Physics department got 2<sup>nd</sup> prize in Rangoli competition.

### INDEPENDENCE DAY COMPETITIONS- SINGING COMPETITION:

In order to encourage the patriotic feel inside the students, the singing competition titled "One Nation, One India" was organized by the Department of Physics. Students from various departments participated and expressed their skills, and they were awarded with prizes and certificates.



### **INDEPENDENCE DAY COMPETITIONS- DRAMA COMPETITION:**

To evolve the positive and Patriotism of the Motherland and to promote the dramatic skills of students with positivity, the drama competition was conducted on behalf of the 75<sup>th</sup> Independence Day. In which, 2<sup>nd</sup> year students from Physics Department won the 1<sup>st</sup> prize.



### **INDEPENDENCE DAY COMPETITIONS- RANGOLI COMPETITION:**

In the view of helping the students to remain in close touch with their culture, Rangoli competitions were conducted. All the spaces of College were filled with the extraordinary colourful Rangolies of the students. Students from department of Physics won the second prize.



### **INDEPENDENCE DAY COMPETITIONS- POETRY COMPETITION:**

In order to encourage excellence in raft of Poetry writing, Poetry Competition was conducted on 16.10.2022 by Vivekananda Higher Secondary School in Kamban Kazhagam in which students of 1<sup>st</sup> year from Department of Physics won II prize by expressing their skill in writing poems.



## FUN FACTS:

1. Saturn can float on water like ice. Saturn is a huge planet, the second largest among the light planets in the solar system. Saturn has a density of less than that of water, around  $0.7\text{g/cc}$ , whereas the density of water is  $1\text{g/cc}$ . According to the theories of floatation, a substance which is less density than liquid floats in that liquid. So, Saturn might literally float on water.
2. The sun doesn't change colour during sunset. This is because the wavelengths of the sun react with the difference in the atmosphere.
3. Time goes faster at the top of the building. According to the famous theory of Relativity by Einstein, the farther an object is from the earth's surface the faster time passes. So, the time goes away fast at the top of the building as compared to the bottom.



**C. Madhumitha**  
B.Sc Physics (1<sup>st</sup> year)

## HAND ART GALLERY



**T. Soundharya**  
B.Sc Physics (1<sup>st</sup> year)

## HAND ART GALLERY



v. Anbarasi  
B.Sc.Physics-I

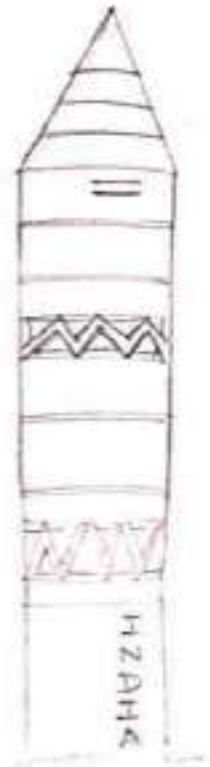

Dr. TESSY THOMAS

# HAND ART GALLERY



V. Sherin

(B.Sc. Physics 3<sup>rd</sup> year)



## HAND ART GALLERY

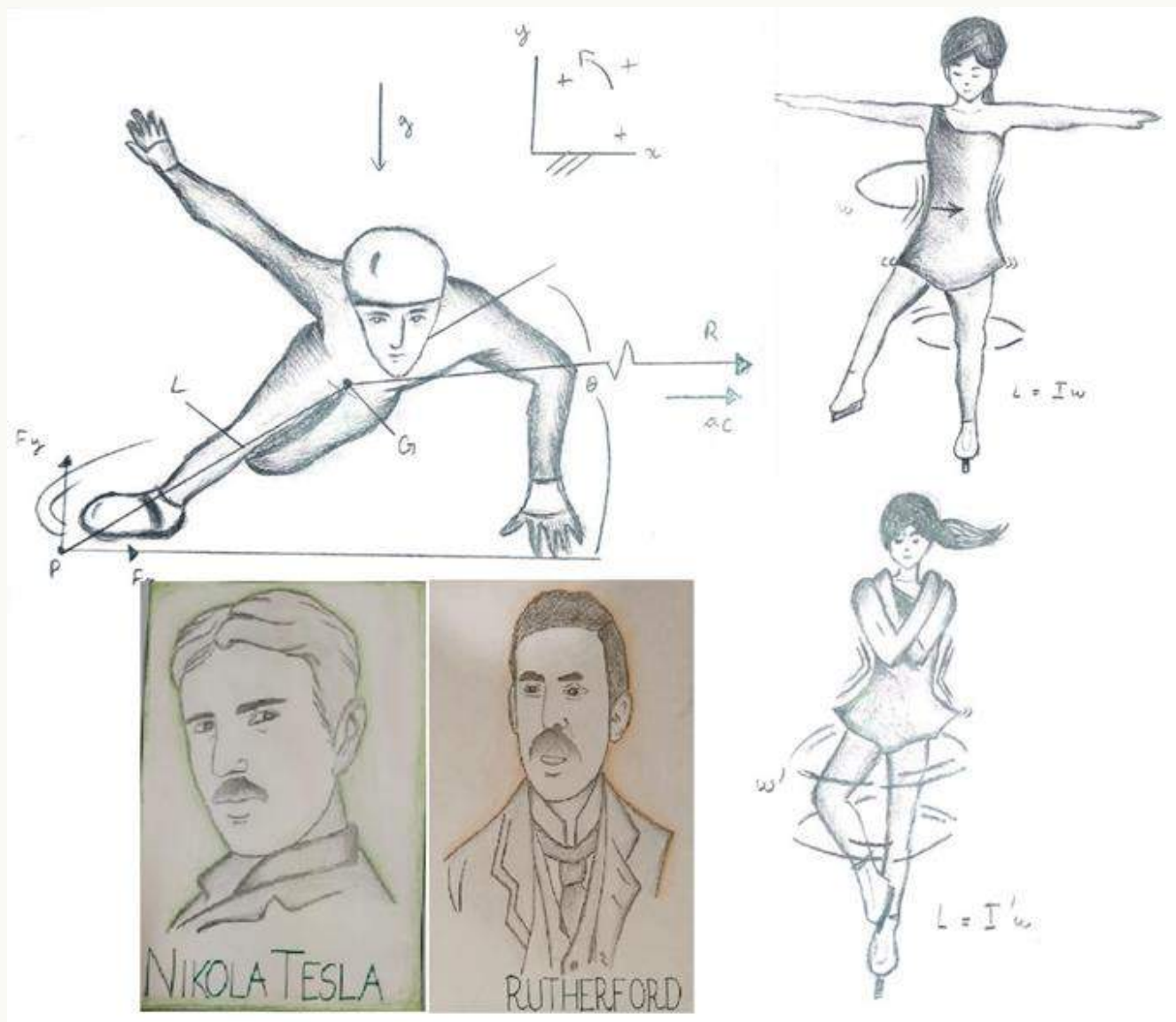

K. Lakshmi Praba

(B.Sc Physics 3rd year)

# HAND ART GALLERY



**K.Karthikeyan**  
(B.Sc Physics 3rd year)

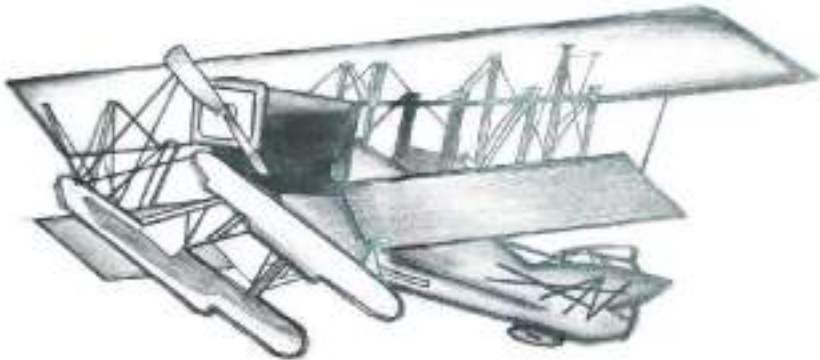

**K.Hindhuja**  
(B.Sc Physics 3rd year)



# HAND ART GALLERY

Pratik

Mirror with  
gliding hole

Sight line

Thinking with  
falsed view obj

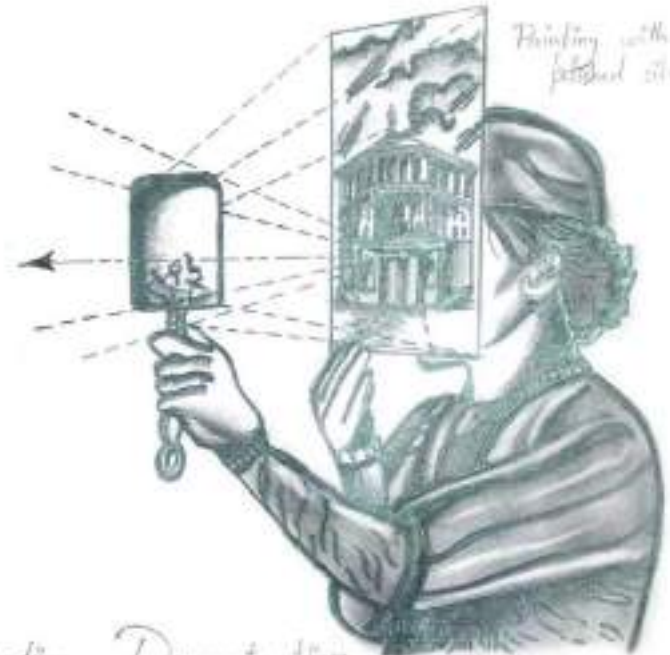

S. Meena / B.Sc. Physics 3rd year

Linear Perspective Demonstration...



**Haini.S**  
B.Sc Physics (2<sup>nd</sup> year)

## இளைஞர்களும் தொழில்நுட்பமும்

காலையரே! மடந்தையரே!  
ஒரு செய்தி உண்டு கேளீரோ!  
ஆதி மனிதன்பெற்ற அறிவே அழலை அறிய செய்தது காலம் மாற  
மனிதனும் மாற பெற்ற அறிவோ வளர்ந்தது  
அறிவின் நீட்சியோ அறிவியல் ஆனது  
அறிவியலின் நீட்சியோ தொழில்நுட்பம் ஆனது  
உழைக்கும் மானுட மனங்களுக்கு அது உற்சாகம் ஆகி போனது  
கண் சிமிட்டும் நேரத்திற்குள் காலை சிற்றுண்டியோ முடிந்தது  
அருகில் இருப்பதன் அருமையை மறைத்தன  
அலைபேசிகளும் அலெக்சாக்களும்  
உடல்வலு இருப்பதன் உணர்வை மறைத்தன  
சாணைகளும் கலவை இயந்திரங்களும்!  
ஆண்டவனே அறியாத விடைகளெல்லாம்  
இன்று கூகுள் ஆண்டவனின் தொடுதிரையில்!  
மானுடத்திற்கே உரித்தான துள்ளலும் உற்சாகமும் முழுதும் ஒருசேர  
பெற்ற இளைஞர்கள் இன்று  
முழுநேரமும் திறன் பேசி என்னும் கூண்டிற்குள்  
காலம் மறந்து சுயமும் மறந்து கானல்  
திறன்பேசியின் வெளிச்சத்தில் நாம்!  
அறிவை அழிக்க உடலை அழிக்க  
அலர்ந்த அந்நியர் சூழ்ச்சியோ இவையெல்லாம்?  
போலி மாயைக்குள் விழுந்து விடாதீர்  
பொழுதின் தேவைக்குத்தான் தொழில்நுட்பம்  
சிந்தித்து செயல்படுவீர்!!!



Revathi K  
B.Sc Physics (2<sup>nd</sup> year)

## கொரோனா

Hai கொரோனா!

உன்னால நான் இல்ல fine -னா  
சுத்திசுத்தி வந்தியே மீனா  
துள்ளி துள்ளி ஓடிய மானா  
உனக்கு மருந்து கண்டுபிடிக்கப் போனா  
தேவையான பொருள்தான் காணா  
உன் சுற்றுப்பயணம் போதும் இனி வேணா  
சுத்தி எங்களையும் ஆக்கிடாத வீணா  
நாட்கள் பல கடந்துவிட்டாய் scene-னா  
இருமல் தான் உன்னுடைய sign-னா  
உன்னப் பத்தி பாடினாரு கானா  
2020-ல நீதான் Don-னா  
எங்கள் விட்டு போயிடு நீனா  
இல்லன்னா நாங்க போவோம் soon-னா

## TEACHER

You are compared to a ladder  
To whom I am going to honour  
They work every day and night  
And does everything right  
She appreciates all my creatures  
And gave me a bright future  
She makes my mind and body healthy  
And makes my life joy and worthy  
She is rose in my garden  
Who help me to come away from all the burden  
She is my key to success  
And make me become best in all aspects  
She is the greatest gift that God has given to me  
Without her where would I be?





## மின்சாரக் கனவுகள்

அண்டத்து கருந்துளை அண்டை வந்து - எங்கள்  
ஆர்ப்பரிக்கும் ஆற்றல் - இன் இரகசியம் கேட்கும்  
இயற்பியல் பயிலும் இளஞ்சிட்டுக்கள் - நம்மை  
ஈர்ப்புவிசை நெருங்க தினம்தினம் எத்தனிக்கும்  
உலோகக் கூட்டம் வரிசை போட்டு - எங்கள்  
ஊனின் மின்னோட்டம் கடத்திச் செல்லும் -எங்கள்  
எஃகு உள்ளத்தின் கூறுகள் காண  
ஏணிப் பிடித்து 'நுண்ணோக்கிகள்' ஏறி வரும்  
ஐம்பூதங்கள் ஆள சார்பியல் தந்த ஐன்ஸ்டீன் - இன்  
எச்சங்கள் நாங்கள் ஆவோம்  
ஒற்றை பரிமாணம் அள்ளித்தந்த சூத்திரங்களும்  
நாங்கள் ஆவோம்  
ஒங்கும் அறிவியல் தேவைகளுக்கு உன்னத  
ஒளடதம் அள்ளித்தரும் சகாப்த மருத்துவர்களும்  
நாங்கள் ஆவோம்  
பித்தர்கள் என்று எண்ணலாம் எங்களை  
ஆனால் நாங்கள்  
பால்வெளி அண்டத்தின் கடைசி நட்சத்திரங்கள்!!  
டெஸ்லா விட்டுச்சென்ற கோட்பாடுகள்!!  
நியூட்டனின் ஆப்பிள் பழங்கள்!!  
எடிசனின் மின்சாரக் கனவுகள்!!



Revathi K  
B.Sc Physics (2<sup>nd</sup> year)

## புதுச்சேரி

நீல வானம்

நிவர்த்தியான வடிவம்

துள்ளி மகிழும் கடல் அலைகள் - மனதை

துள்ள வைக்கும் கடற்கரைகள்

அகன்ற சாலைகள்

அழகான சோலைகள்

பார்வை தோறும் பசுமை

இங்கில்லை வெறுமை

முன்னோர்கள் நினைவிடம் - அது

மன அமைதி தரும் இடம்

இயற்கையைப் போற்றும் இடம்

இன்னல் இல்லாது வாழும் இடம்

பெயரிலே தனித்தன்மை

புகழிலே தனிப்பெருந்தன்மை

கவிஞர்கள் போற்றும் பகுதி - இங்கு

வாழ்வோரின் எண்ணிக்கை மிகுதி

சாதி மத பேதத்திற்கு தடை இல்லை - என்பதற்கு

சாட்சி எங்கள் மொழி எல்லை

சுற்றுப்பயணம் செய்வதற்கு சிறந்த இடம்

சுற்றி வந்தால் குளிர வைக்கும் தகுந்த இடம்

இதன் சிறப்பை சொன்னால் முடியாது

அதற்கு கடை எல்லையும் கிடையாது

இங்கில்லை அடிமை எனும் கரி

இது மக்களைக் கூட்டிச் சேர்க்கும் தறி

அது நான் வாழும் புதுச்சேரி.....!!



Sr. Merculin Brindha  
B.Sc Physics 3<sup>rd</sup> year

## JUST ONE

One song can spark a moment  
One flower can wake the dream  
One tree can start a forest  
One smile begins a friendship  
One star can guide a ship at sea  
One word can frame the goal  
One vote can change the nation  
One sunbeam lights a room  
One candle wipes out darkness  
One step must start each journey  
One word must start each prayer  
One touch can show you care  
One heart can know what's true  
One life can make a difference  
You see, it's up to you!

### 10 Professions of the Almighty

#### Creator

He creates the world every moment  
Which the creatures praise like a diamond  
Reveals himself in all the testament  
He gives his life as a payment

#### Redeemer

He redeems the world by his precious blood  
He falls for the people on the glorious mud  
He gives his life for the beautiful buds  
He humbles himself like a golden wheat

#### Master

He is a super master  
Leads us to the green pasture  
Shape us as the good  
Make us pure by the holy water



### **Preacher**

He is a peaceful Preacher  
Gives him as a powerful teacher  
Made me such a wonderful searcher  
He is my lovely heart-toucher

### **Caller**

He is a True caller  
He wants me to become a great scholar  
He invites me in his own parlour  
And makes me like a chill air cooler

### **Carpenter**

He takes role as a carpenter  
He shapes me like more wonder  
He comes to me as a lighting thunder  
And blesses me with every splendor

### **Fisher**

He is a well-known fisher  
He does all my wishes  
And gives me his own dishes  
Make my evil spirit ashes

### **Doctor**

He is my family doctor  
He makes me well and better  
He speaks to me through his letter  
And makes my life as a glitter

### **Healer**

He is the silent healer  
He signs with all the dealers  
He is my safety kneeler  
He makes Satan always fooler

### **Lover**

He is my non-stop lover  
He is my best giver  
He is my life driver  
He is my all the power



### **FRESHER'S DAY:**

The most remarkable event of the college “Freshers Party” held 16<sup>th</sup> of November 2022. Staff and Senior Students made it a memorable day for the fresher's of the academic year 2022-2025. Dr.E.M. Rajan, Retired Professor, Tagore Arts and Science College was invited as the chief guest. The day helped the senior students in building the bond with their Juniors.



### **CHRISTMAS CELEBRATION:**

Our college celebrated Christmas on 24<sup>th</sup> Dec 2022. The campus was well decorated with cribs, Christmas trees, stars and bells by the Students of Department of Physics. The boundless joy of celebrating the festival was visible on the faces of the students. Parents of final year students were invited as the Chief guests for the celebration.



### **PONGAL CELEBRATION:**

Idhaya College celebrated the Pongal celebration on 13<sup>th</sup> January 2023 in a memorable manner, which will be evergreen in the memory of all the students. The specific places were allotted for all the departments. The Place behind the Idhaya convent was allotted for the Department of Physics. The students cleaned their respective place and decorated with the hanging decorators. The staffs and students of the Department prepared Pongal and other traditional food items like Sundal, Kesaries etc. In the view of honoring the farmers, one of the farmers who is the father of our student were invited as the Chief Guest. Various traditional games like “Uri adithal” were conducted.



### **EDUCATIONAL TOUR TO MUNNAR:**

An education trip to Munnar was organized by Idhaya college from 16.02.2023 to 19.02.2023. The tour was based on discovering new insights to practice. Students were given an opportunity to travel over new places



and they also enjoyed fun activities like trekking, campfire on the first day of the trip. On the second day, students were taken to Lukkem falls to experience nature's laughter. Finally the students were taken to Pazhani to experience spirituality and to express their gratitude.

### **EDUCATIONAL TOUR TO OOTY:**

The major lure of Ooty is its beauty. Students of second year Physics Department were taken to Ooty which was organized by Idhaya college on 19.02.2023 to 22.02.2023. The star attraction of the trip in Ooty is the tea estate, lakes tea and chocolate factories.



Students also visited the temple named Muthumalai Murugan Temple that is situated at Salem. This educational tour made the students to manage their works by themselves and helped them mingle with fellow students in these types of tours.

### **INTERNATIONAL WOMEN'S DAY:**

Idhaya college celebrated International Women's day on 8<sup>th</sup> March 2023. The district collector Mr. Manikandan was invited as the Chief Guest and the function started with his speech about the role of women in all fields of life and about the importance of International Women's day.

Students from all the departments showed their individual talents hidden inside them on making their own individual stalls.

The programmes like Therukoothu, Parai Isai, Classical dance and Kaviaragam



enunciating the Pride of Women in Sangam and Modern Era.

District collector inaugurated the shopping complex of the students. This programme made the students to turn their passion towards the field of Entrepreneurs.

### **FAREWELL:**

In an emotionally surcharged atmosphere inside Idhaya Campus, the students, faculties and management of Idhaya College bid adieu to the students for the batch 2019-2022 at a grand farewell ceremony on 30.07.2022. Various fun filled activities were organized by the I and II year students made everyone mushy. These activities filled their hearts and minds with their unforgettable memories in those past three years.



## 11<sup>TH</sup> CONVACATION DAY

Idhaya College of Arts and Science for Women, Pondicherry celebrated its 11<sup>th</sup> Convocation ceremony on 11.06.2022. Dr. K. Chandra Sekhara Rao, Dean (i/c) Pondicherry University was invited as Chief guest and along with the dignitaries honored the gold medalists and toppers of the batches 2014-2017, 2015-2018 and 2016 to 2019.



A total of 130 students got their graduation certificate from the Department of Physics. All the graduates were very happy on receiving their own recognition and laurels.

### UNIVERSITY GOLD MEDALIST:





**UNIVERSITY GOLD MEDALIST:**



**ACHIVEMENTS:**



## PHOTO GALLERY



## PHOTO GALLERY



## PHOTO GALLERY



# PHOTO GALLERY



# PHOTO GALLERY

